

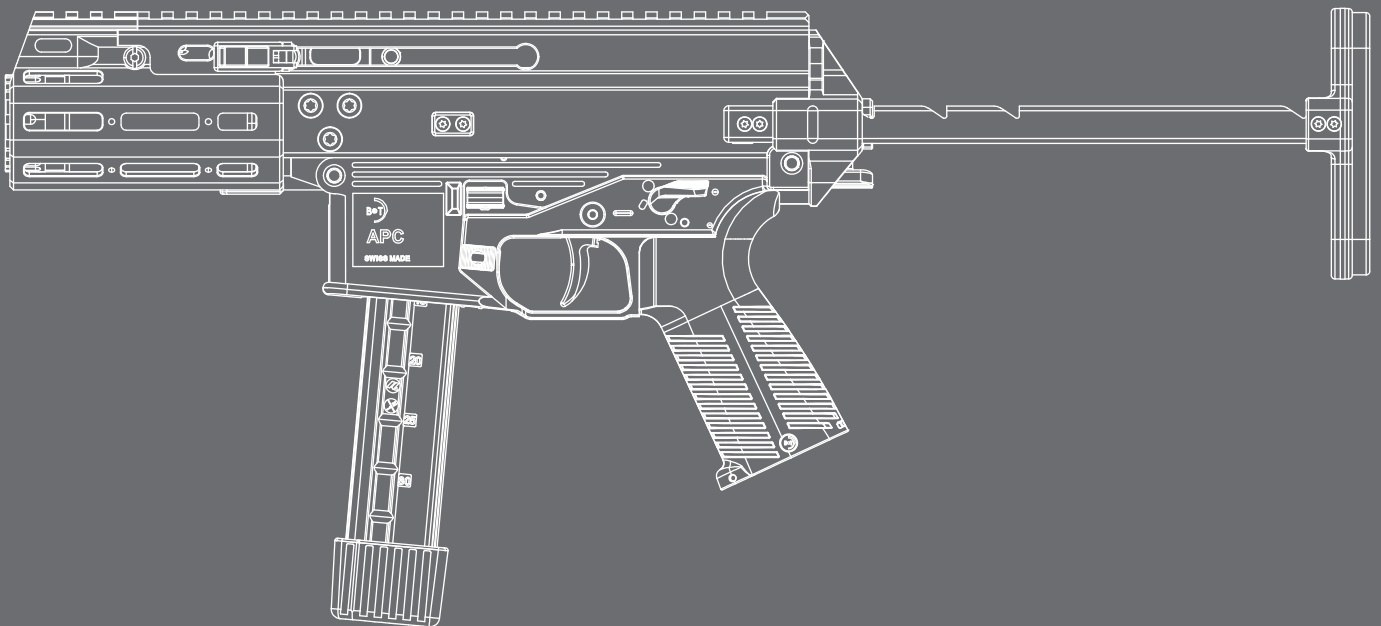

APC 9K & APC 9K SD²

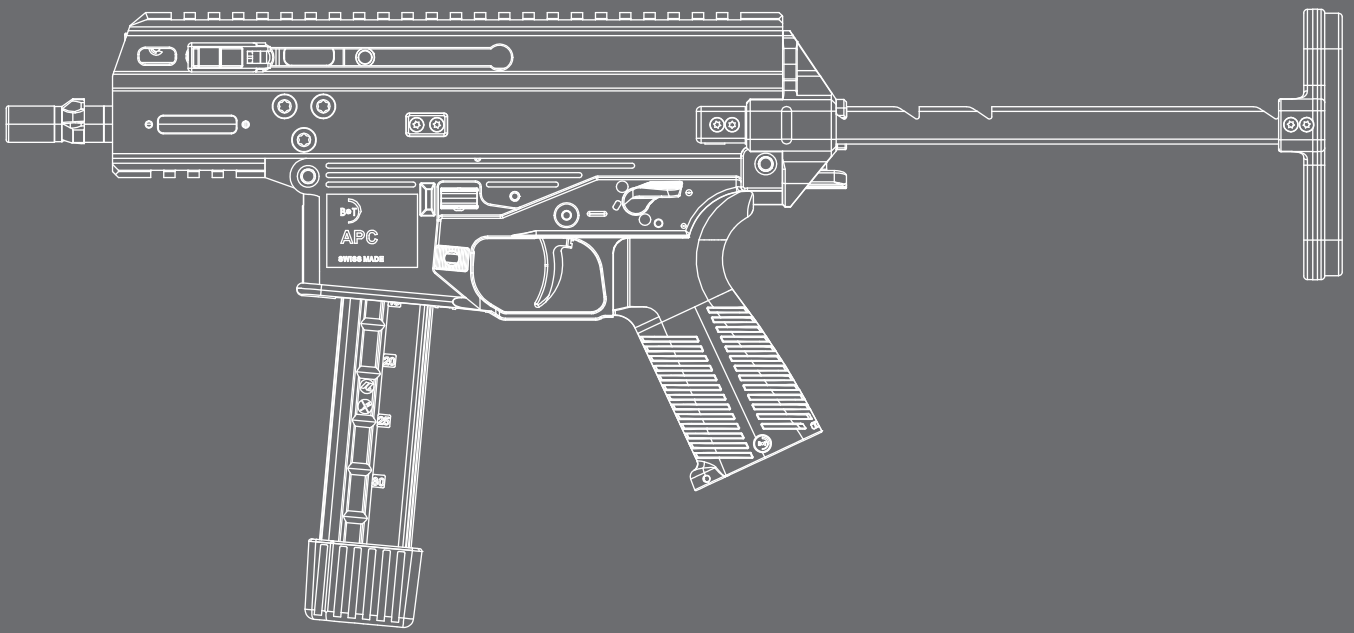

TECHNICAL MANUAL

WARNINGS

- Do not load or fire this airsoft gun until you have completely read this manual and are familiar with its safety features, mechanical operation, and handling characteristics.
- Handle this and any airsoft gun as if it were loaded at all times.
- Keep your finger off of the trigger until ready to shoot.
- Do not look down the barrel of a airsoft gun. Accidental discharge into the eyes may cause permanent injury or death.
- Keep the airsoft gun on safe until ready to shoot.
- Keep the barrel plug (user supplied) installed on airsoft gun when not shooting.
- Never point the airsoft gun at anything you do not intend to shoot.
- Never fire your airsoft gun at anything you do not intend to shoot because there may be BBs or foreign debris lodged in the chamber, and / or barrel
- Do not shoot at fragile objects such as windows.
- Never fire your airsoft at personal property of others
- Always keep the muzzle pointed in a safe direction, even if you stumble or fall.
- Eye, face, and ear protection designed specifically to stop BBs in the form of approved goggles, and face protection should be worn by the user and any person within range.
- Never shoot at a person who is not protected by eye, face, and ear protection designed for airsoft.
- Before storing or disassembling, be sure to point your airsoft gun in a safe direction, fire several times to be sure there are no BBs lodged in the chamber and / or barrel. Install barrel plug.
- Store the airsoft gun unloaded in a secured place.
- Use only high quality new 6mm BBs. Used or damaged BBs may cause a malfunction.
- Avoid alcoholic beverages before and during the use of this airsoft gun Handling airsoft guns while under the influence of drugs or alcohol is a criminal disregard for public safety.
- Avoid shooting an opponent at point blank, 2 Meters or less.

SPECIFICATIONS		MANUFACTURER INFORMATION
Product Name:	B & T Air APC9 K B & T Air APC9 K SD ²	ARCHWICK Company of New Taipei City, Taiwan was founded in 2019. It specializes in airsoft guns, accessories, and other upgrade parts. It prides itself on making products of exceptional quality and value.
Materials:	Aluminum / Polymer S45C Carbon Steel	
Finish:	Hard Coat Anodized	
Length:	3750 - 5530mm	
Weight:	2350 - 2500g	
Barrel Length:	129mm	
Magazine Capacity:	20 / 30 RDs	
Power Source:	Gas or CO2	
Caliber:	6mm Airsoft BB	
Power:	<0.20J (Korea) <0.98J (Japan) <1.30J (Other Markets)	
		<p>UNDER PROMISE, OVER DELIVER</p>



The B & T Logo and all intellectual properties associated with this replica airsoft product are used under license by B & T AG of Thun, Switzerland. For more information on B & T AG and its products, visit: www.bt-ag.ch



MANUFACTURED
IN TAIWAN



For more information on ARCHWICK / B & T Air, visit us online or follow us on:



Thank you for choosing B & T Air by Archwick! Your APC9 Series Gas Blow Back Small Machine Gun requires some minor assembly before it is ready for use. Please follow this guide or scan the QR code below for our detailed instructional videos.



SAFETY

EXCEPT WHEN THE AIRSOFT GUN IS IN USE, ALWAYS MAKE SURE THAT THE BARREL PLUG IS INSTALLED AND THE SELECTOR SWITCH IS IN SAFE MODE, WHICH DISABLES THE TRIGGER.



The APC9 GBB's comes with an ambidextrous selector switch / safety.

Rotate counterclockwise to move to the SAFE position.

Rotate clockwise to the SEMIAUTO position

Rotate clockwise to the FULL AUTO position.

(The Full Auto Feature may be disabled for those regions that prohibits Full Auto Fire Mode)

STEP 1. Flip Up Sights Installation (Optional)



Position front and rear sights to the desired rail position, insert included screw.

Tighten screws with 2.5mm Allen wrench.

STEP 2. Side M-LOK Accessories rails (Optional)

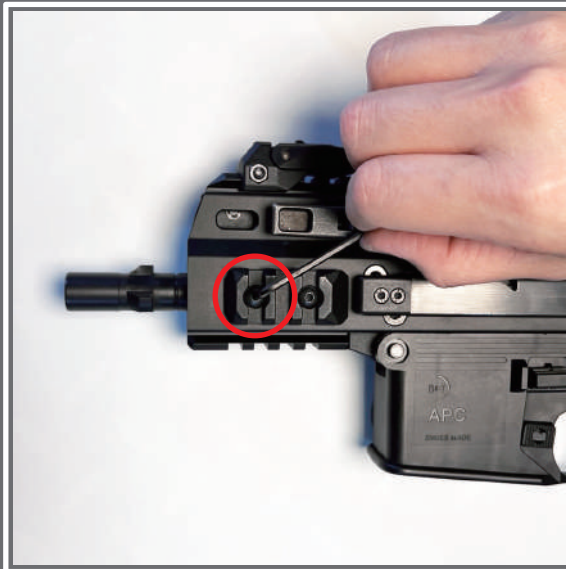
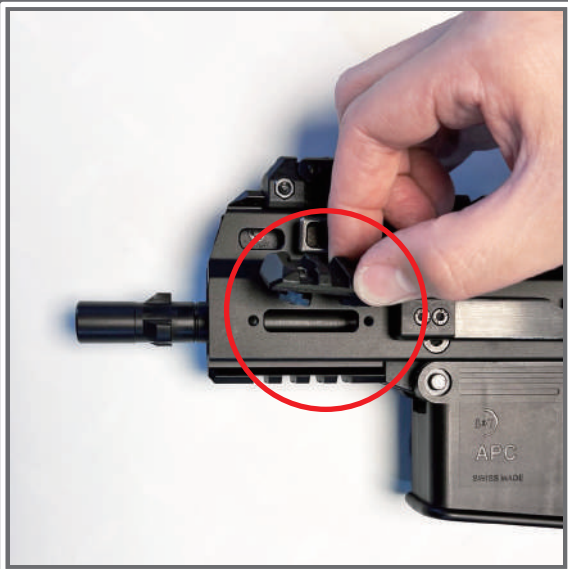

Position side rails onto the slots located onto the sides of the gun.

Position locking lugs into slot, tighten screws with 2.5mm Allen Wrench.

STEP 3. Front Sling Mount / Hand Stop (Optional)

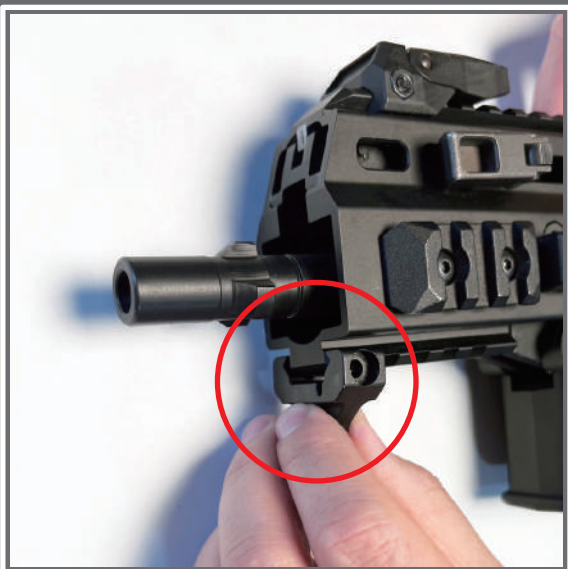

Position sling mount on the desired bottom rail position, insert and tighten screw with 2.5mm Allen Wrench.

STEP 4A. Filling the Gas Magazine

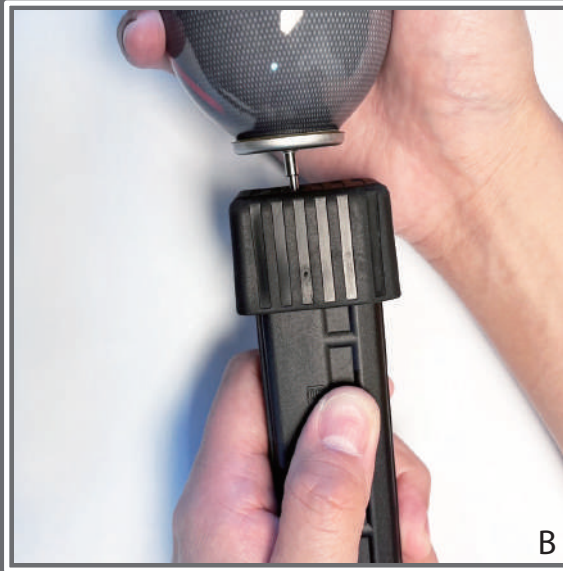
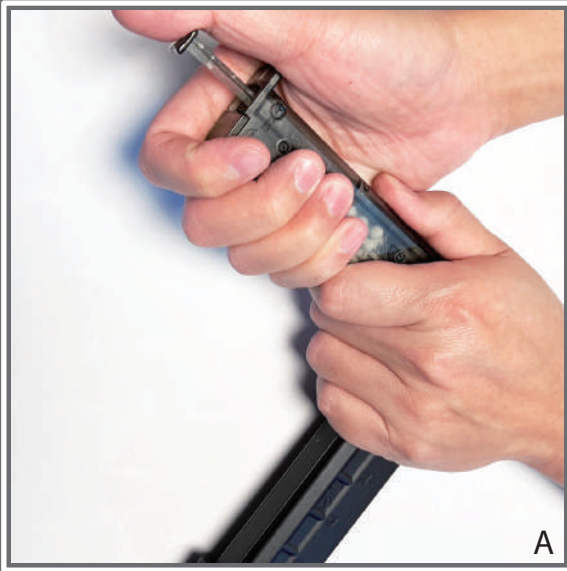

A. Loading BBs.
Load magazine with self supplied BB loading tool to capacity.
※ Do NOT overfill.

B. Loading Gas.
Invert magazine, insert gas can filling stem into magazine.
※ Push and hold gas can down for approximately 4 to 5 seconds.

Do NOT under or over fill the magazine.

※ For a more precise gas fill, we recommend weighing the magazine before and after filling.
The optimal capacity of your APC9 magazine is 8 to 12cc of gas (8 - 12g)

STEP 4B. Filling the CO2 Magazine

WARNING!!! Please familiarize yourself with the proper handling and special characteristics of CO2 gas and 12g disposable canisters before using CO2 magazine. Improper handling can lead to possible injuries or damage to the magazine or airsoft gun.

WARNING

Use only 12g CO2 capsules. Any attempt to use other types of gas capsules could be extremely dangerous and could result in serious injury or death. Gases other than CO2 could result in an explosion or rupture of the airsoft gun.

CAUTION

Keep hands and face away from escaping CO2 gas. It can cause frostbite if allowed to come in contact with skin. Always make sure the CO2 capsule is empty before attempting to remove it from the airsoft gun by slowly turning the gas capsule puncture screw counter-clockwise all the way until you no longer hear the escape of CO2 gas.

NOTE

A slight seepage of CO2 may occur until piercing screw is tight.

NOTICE

Never try to force any CO2 capsule into or out of place. Do not store your airsoft gun with a CO2 capsule in it. If you know you will not be using your airsoft gun for an extended period of time, empty the CO2 capsule and remove it from the airsoft gun. This is very important to remember, as it will prolong the longevity of your airsoft gun seals.

WARNING

CO2 capsules may explode at temperatures above 122F or 50 C. Do not mutilate or incinerate them. Do not expose them to heat or store CO2 Capsules at temperatures above 122F or 50 C.

CAUTION

Never attempt to reuse a CO2 capsule for any purpose. Always check to make sure the airsoft gun is unloaded when getting from storage or from another person.

STEP 4B. Filling the CO2 Magazine Continued / Installing Removing Disposable 12g CO2 Canisters



A. Loading BBs. Load magazine with self supplied BB loading tool to capacity.
※Do NOT overfill.
(See step 4A)

Remove rubber boot to expose CO2 piercing screw

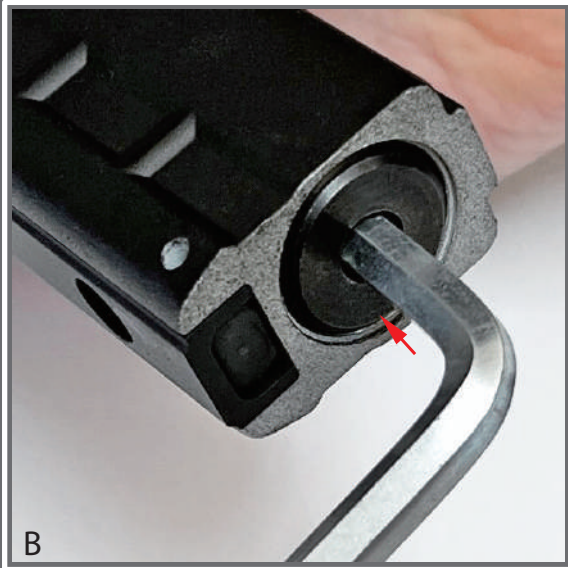

B. Insert 5mm Allen Wrench, rotate counterclockwise to loosen / remove piercing screw.

WARNING!!!

When removing a spent CO2 canister loosen piercing screw slowly to allow any remaining gas to escape before completely removing piercing screw.



C. With piercing screw removed, insert new disposable 12g CO2 canister.

Install piercing screw and turn clockwise to tighten / pierce CO2 canister.

Re-install rubber boot

STEP 5: INSERT/ REMOVE MAGAZINE



- A. Insert magazine directly up into the magazine well, you should hear an audible 'click' when it's properly seated.
- B. To remove / change a magazine, push down on the magazine release on either side of the gun.

Pull magazine down to remove from gun.

STEP 6A: CHARGING THE AIRSOFT GUN

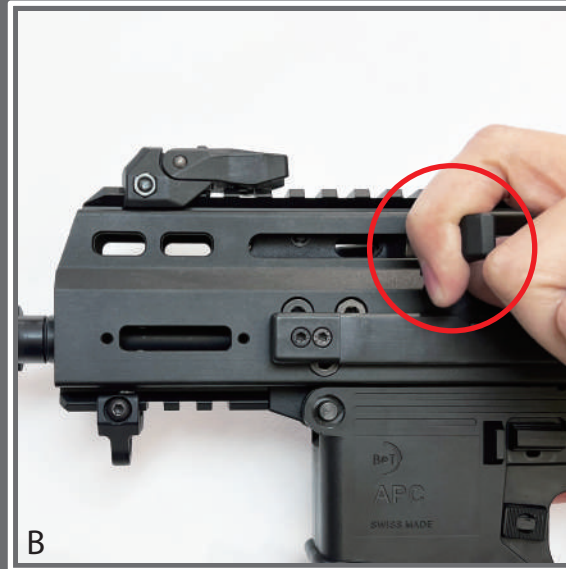
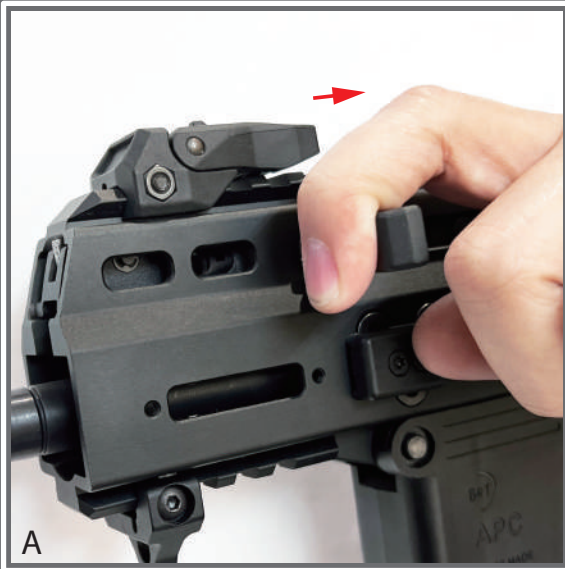

- A. Lift and grab charging handle from either side of the gun and pull straight back until it stops, release charging handle and it will spring forward.
- B. Your Airsoft gun is now charged, disable safety when ready to use.

※ Your APC9 series GBB comes with ambidextrous charging handles, located on the front / top of the gun, the handles are spring loaded, and will retract automatically when released. The charging handle does not move with the bolt.

STEP 6B: CHARGING THE AIRSOFT GUN FROM BOLT LOCK



- A. Remove empty magazine and insert a loaded one; push down on the bolt release button on either side of the gun.
- B. Your bolt carrier will slide forward, load a new round, and go back into battery.

※ Your APC9 series GBB comes with ambidextrous bolt releases, located on the sides of the gun, above the magazine release buttons. Your bolt will lock open after the last round in the magazine is fired. (Last Round Bolt Open Feature)

STEP 7: EXTENDING / RETRACTING THE TELESCOPING STOCK



A-1. Hold the gun firmly by the grip with one hand and hold down the stock release button.

A-2. Grab the stock as shown, pull straight back to the desired position and release the button.

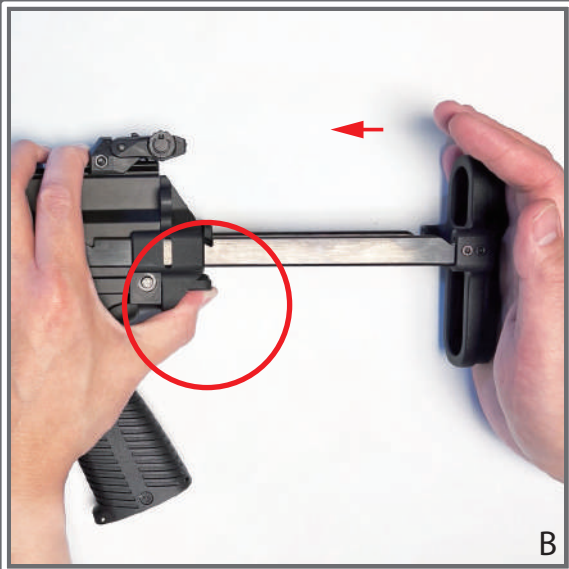

B. To retract the stock, push and hold down the stock release button, and push the telescoping stock back into the gun.

STEP 8: ADJUSTING THE HOP UP

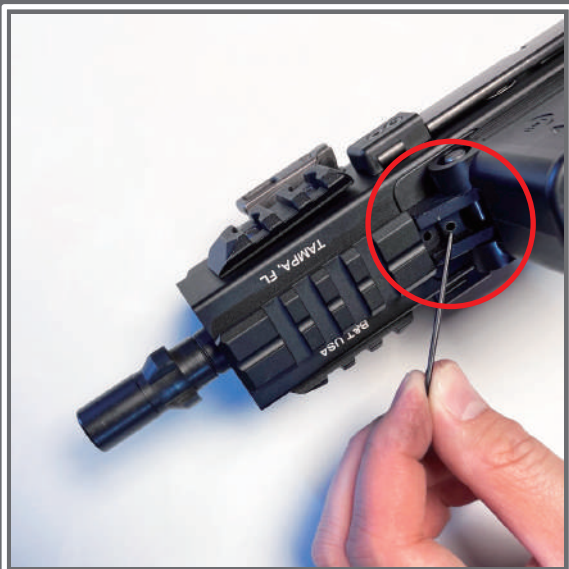

The hop up adjustment screw is located on the bottom of the gun, directly in front of the magazine well.

Insert 1.5mm Allen Wrench, turn clockwise to increase hop up, counter-clockwise to decrease.

ACCESSORISATION: Installing 14mm CCW Thread Adaptor / Changing Hop Up Bucking or Inner Barrel

Your APC9 series GBB comes with a steel tri-lug muzzle device pre-installed onto the factory steel barrel. We have also included a 14mm counter clockwise thread adaptor, which can be used to attach aftermarket accessories such as tracer units. Installing the thread adaptor will require the removal of the outer barrel and hop up unit. Additionally, if you wish to change the hop up bucking or inner barrel, you can follow the same steps.

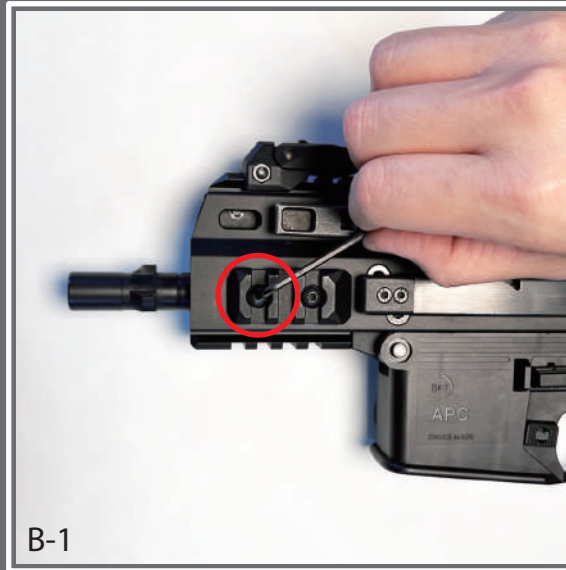
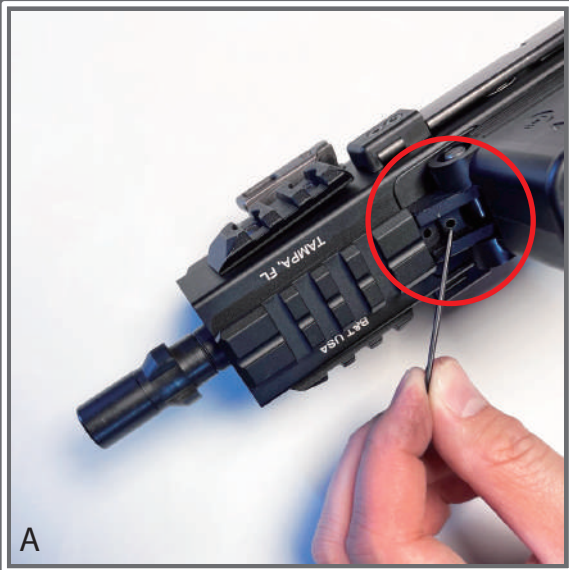

A Completely loosen the hop up adjuster with 1.5mm Allen Wrench. Turn clockwise to loosen.

B-1. Loosen side M-LOK accessories rail screws with 2.5mm Allen Wrench

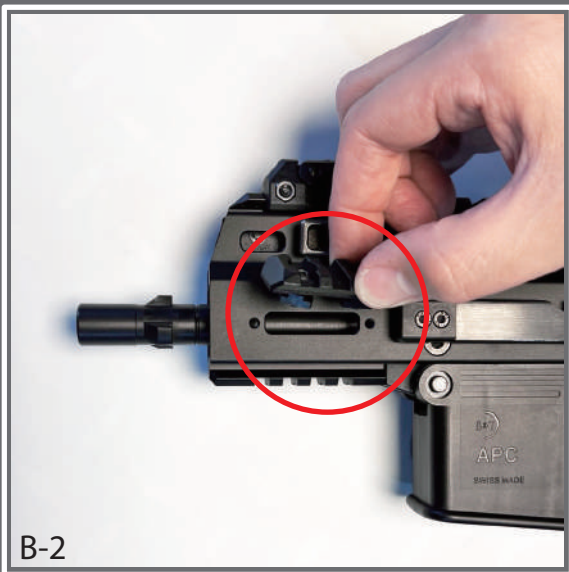

B-2. Remove accessories rails and locking lugs on both sides of the gun.

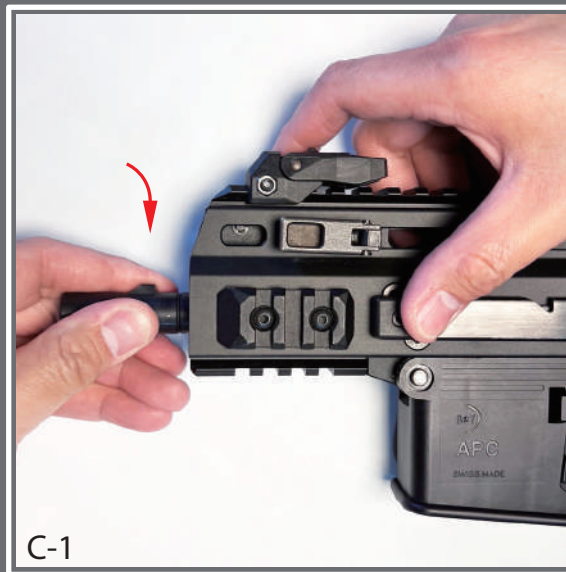

C-1. Hold the gun firmly by the receiver with one hand, and loosen the muzzle device with the other.



C-2. Turn muzzle device clockwise to remove from the barrel. (the muzzle device has its own thread adaptor attached)

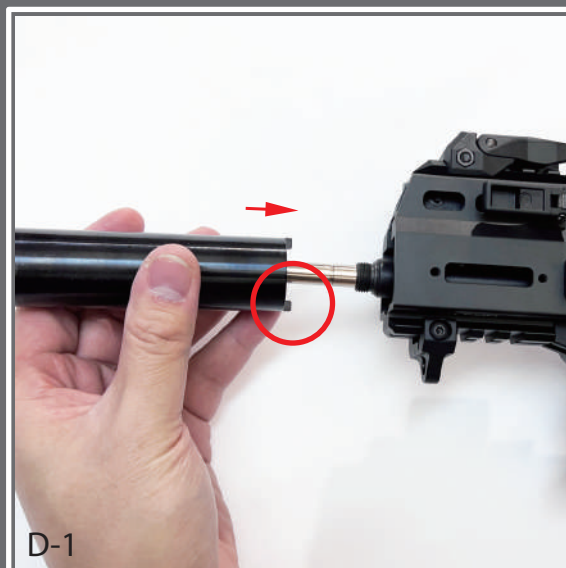

D-1. Insert barrel install / removal tool. (included in your box)

Note that the side with the lugs go into the gun.



D-2



D-3

D-2 Turn barrel tool slowly by hand until the lugs lock onto the barrel nut.

D-3. Insert self supplied screw driver through the holes of the barrel tool. Turn counterclockwise to loosen the barrel nut..

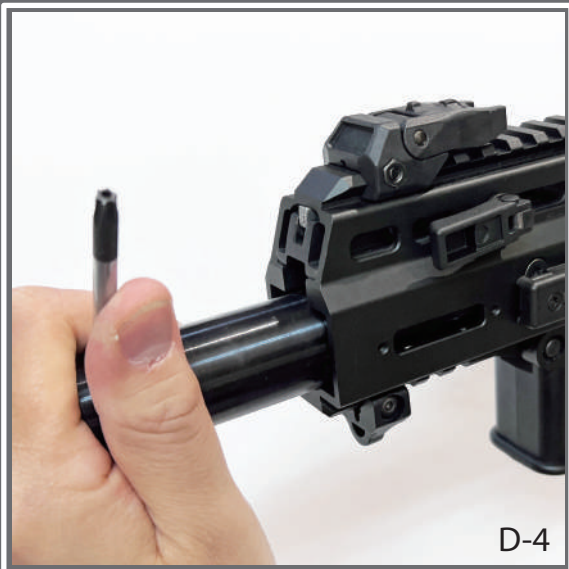

D-4

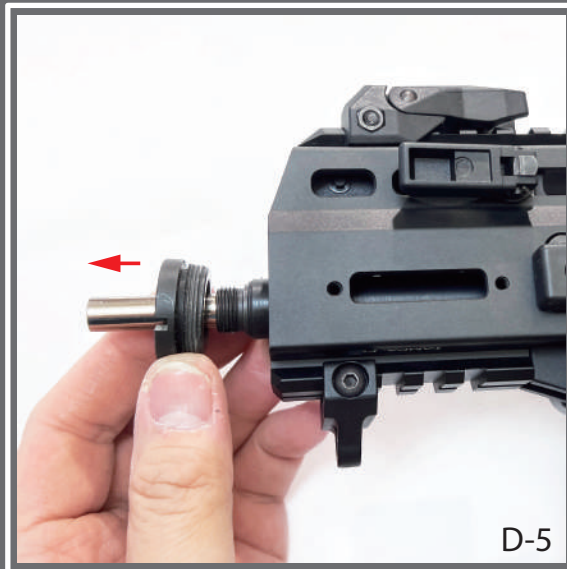

D-5

D-4 Keep turning the barrel tool until the barrel nut is completely loosened.

D-5. Remove barrel nut from the gun.

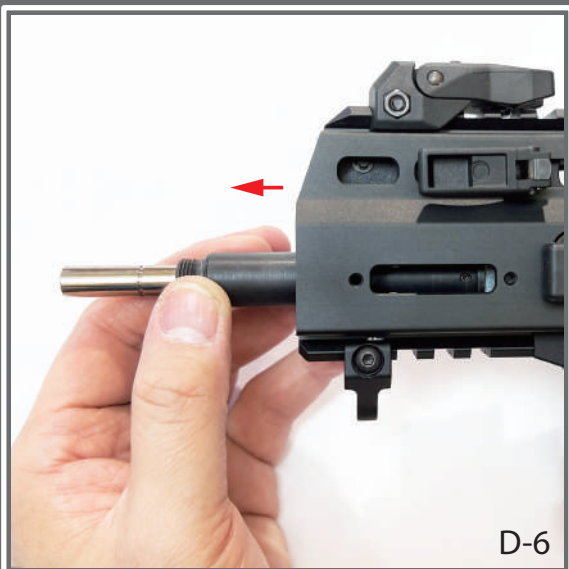

D-6

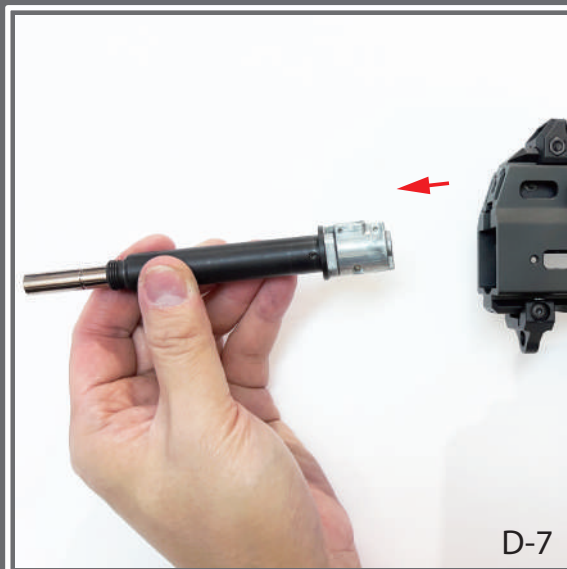

D-7

D-6 Grab the outer barrel by hand and wiggle it side to side to loosen it from the gun.

D-7. Pull out the outer barrel and hop up chamber.

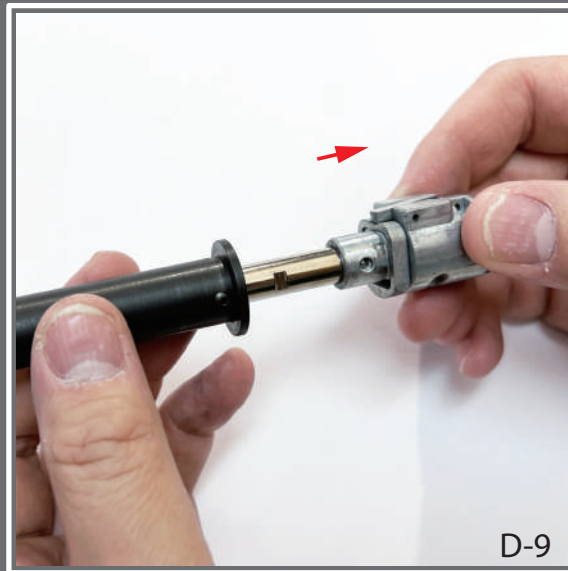

D-8. Remove outer barrel set screws with 1.5mm Allen Wrench.

D-9. Pull out the outer barrel.

Skip steps E if you do not wish to change out the standard thread adaptor to the 14mm CCW version. See steps F for hop up bucking and / or inner barrel change.

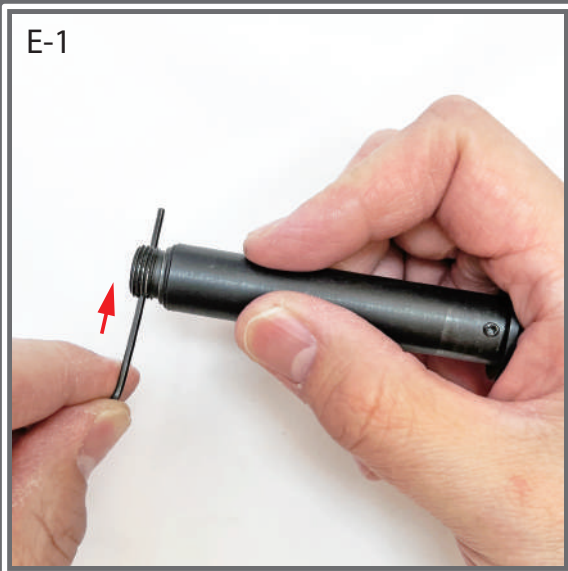

E-1. Insert 1.5mm Allen Wrench through holes of the standard thread adaptor

E-2. Turn counterclockwise until the thread adaptor is completely loosened.

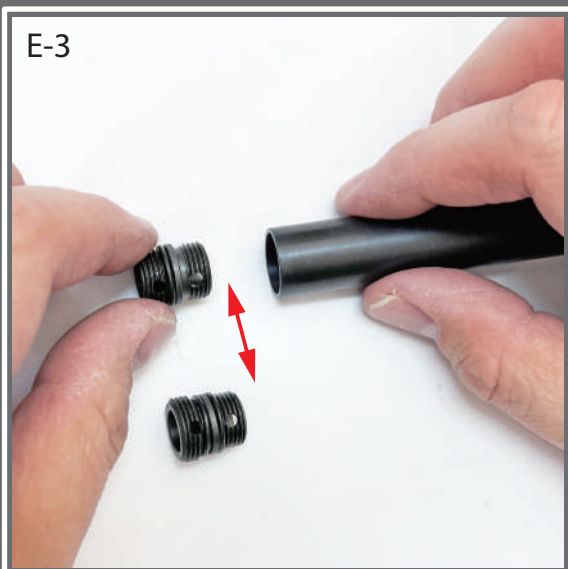

E-3. Swap out original thread adaptor with 14mm CCW version. Keep original in a safe place.

E-4. Screw 14 CCW adaptor into outer barrel.

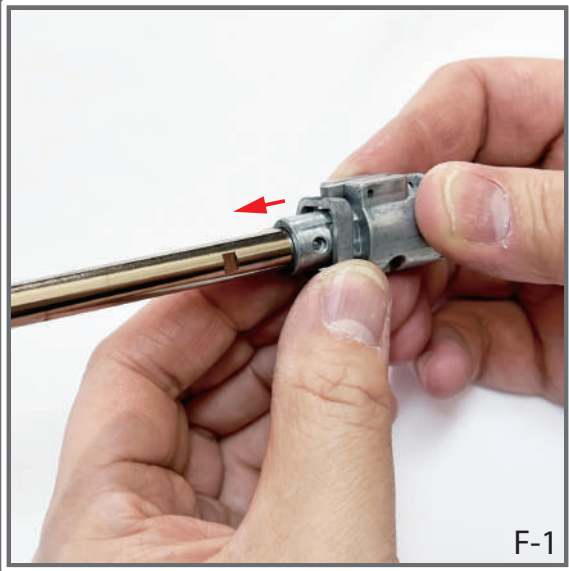

F-1

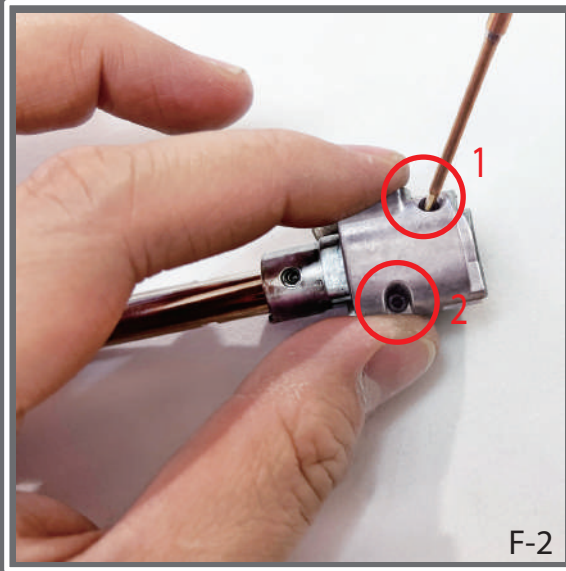

F-2

F-1. Slide hop up chamber retainer forward and remove from hop up chamber.

F-2. Remove hop up chamber screws with 1.5mm Allen Wrench

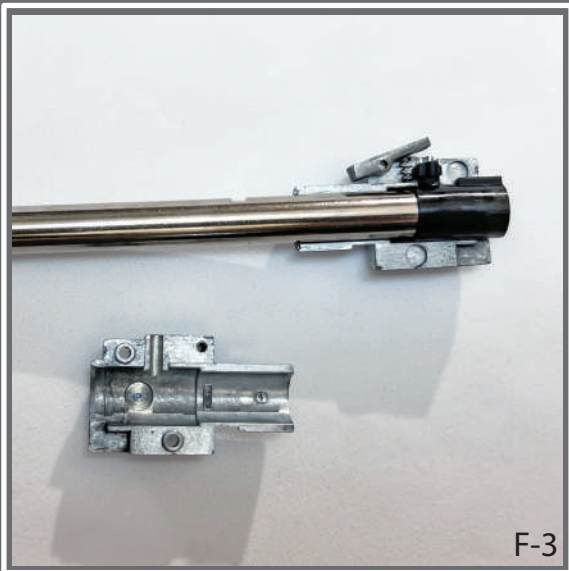

F-3

F-3. Remove 1 side of the hop up chamber body to expose the hop up bucking, pressure pad, and inner barrel. Be careful not to lose the hop up arm spring. Replace hop up bucking / inner barrel as desired, and reverse the take down process to reassemble the hop up chamber.

Factory Hop Up Bucking Spec:

Archwick Trident 70 Degrees NBR - GBBR (MWS Spec)
SKU: AW-BUC-GBB-N3

Factory Hop Up Pressure Pad Spec:

Archwick TYPE A 70 Degrees NBR- GBBR (MWS Spec)
SKU: TA-002

Factory Inner Barrel Spec:

Archwick 6.03mm 129mm Precision Polished Tightbore Barrel
SKU: AW-TBB-G129

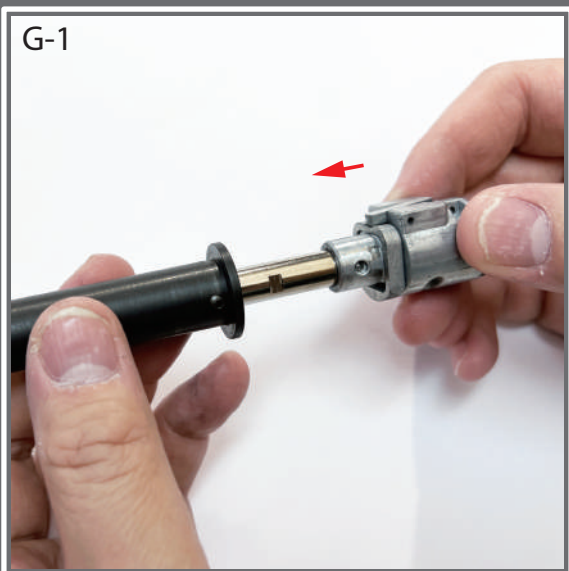

G-1

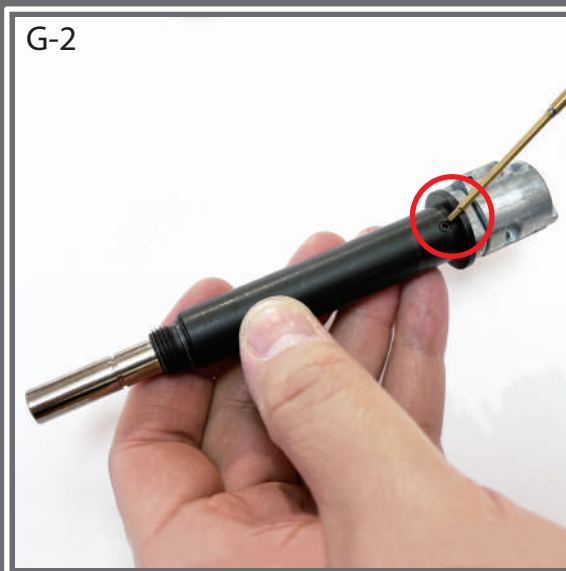

G-2

G-1. Slide reassembled hop up chamber into the outer barrel.

Note the orientation of the barrel and the hop up chamber.

G-2. Insert set screws and tighten with 1.5mm Allen Wrench to secure the hop up chamber to the outer barrel.

G-3



G-4

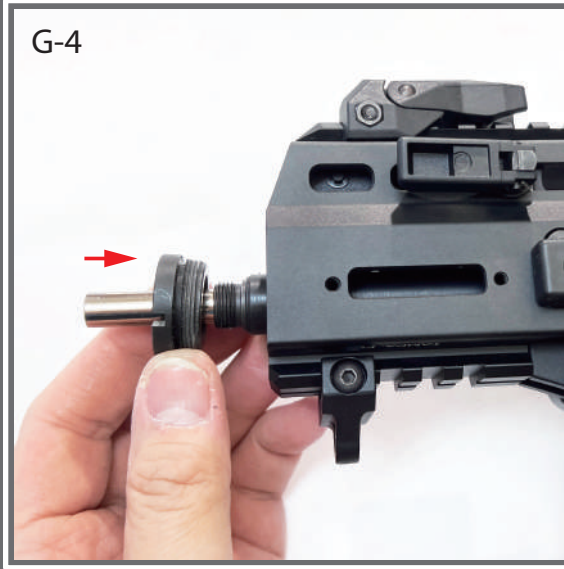

G-3. Insert outer barrel assembly into the receiver as shown, push barrel in until it is fully seated.

G-4. Insert barrel nut, ensure that the threads are facing inward.

G-5



G-6

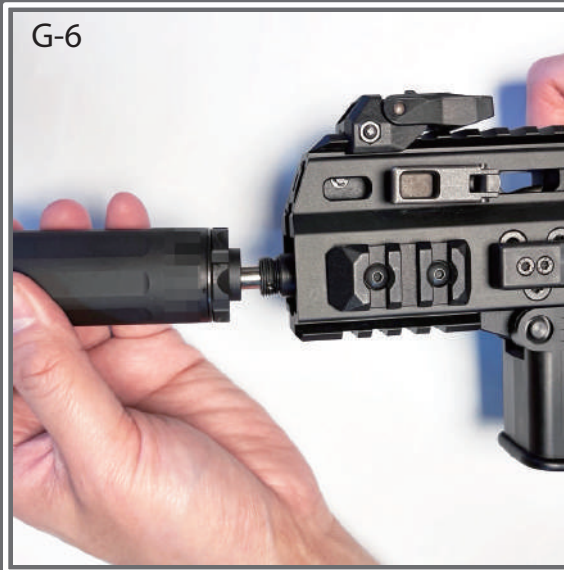

G-3. Insert barrel tool and turn clockwise to tighten barrel nut.

G-4. Re-install factory muzzle device, or install desired aftermarket accessory if using 14mm CCW adaptor.

For additional technical and maintenance related information, please go to www.arch-wick.com or scan QR Code on page 3 to go directly to our official youtube channel on your mobile device to watch our instructional videos.

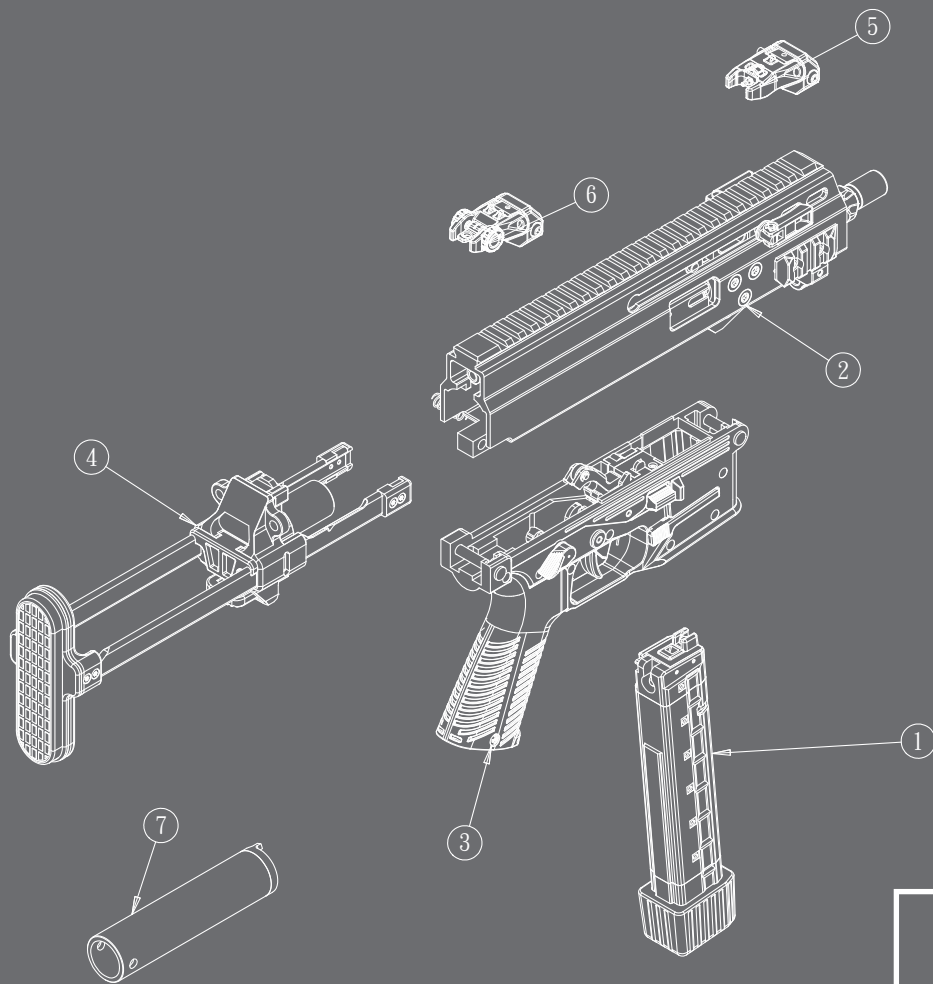

MODULE A

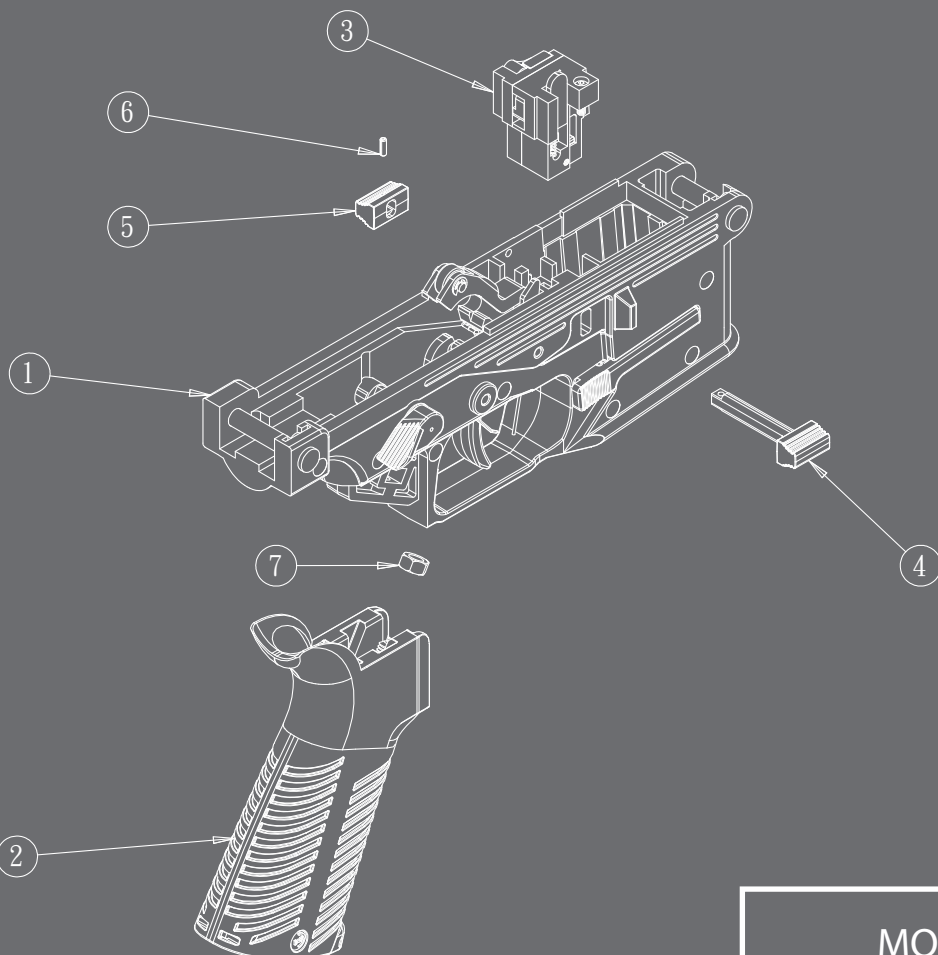

MODULE B

APC 9K

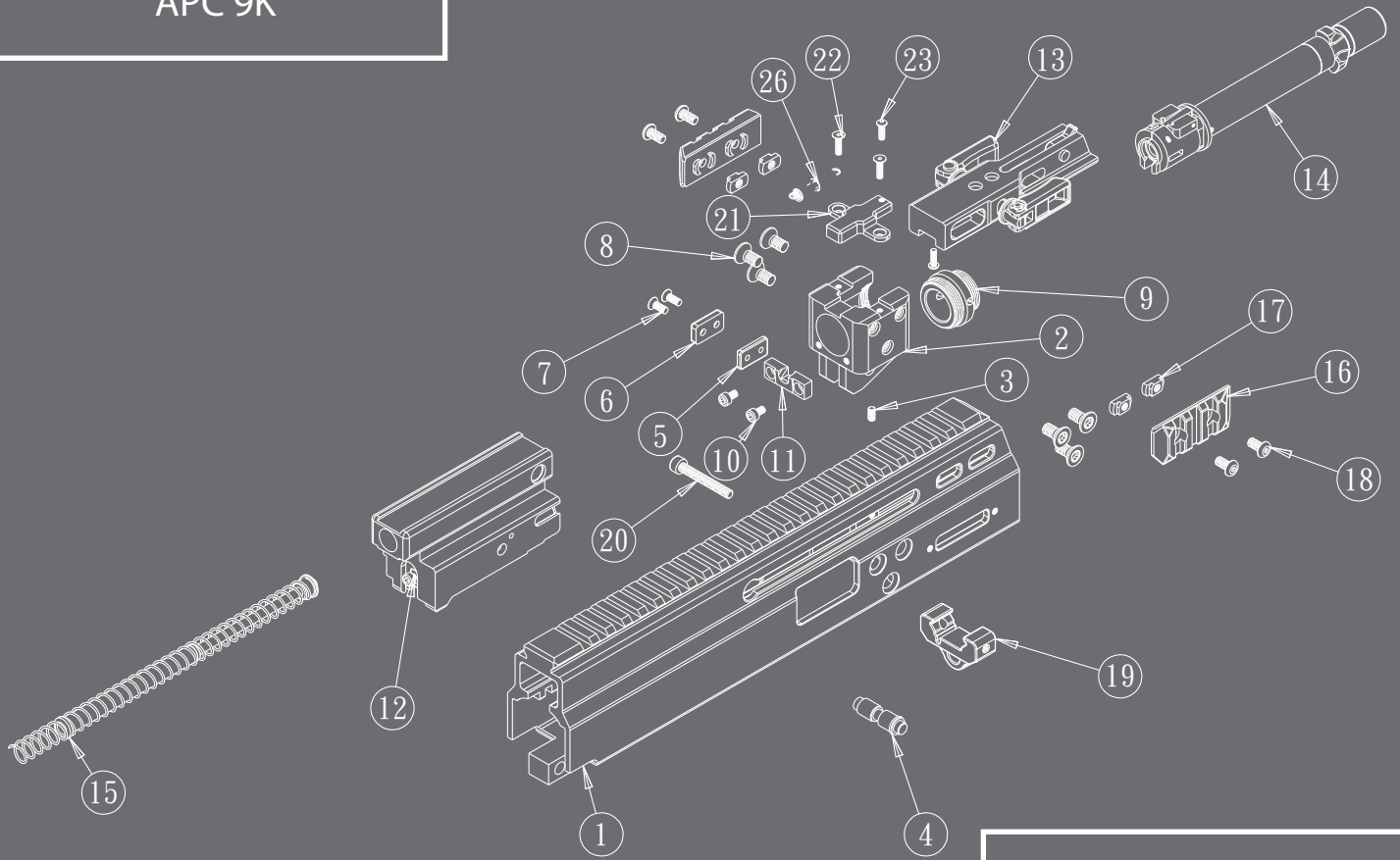

MODULE C

APC 9K SD2

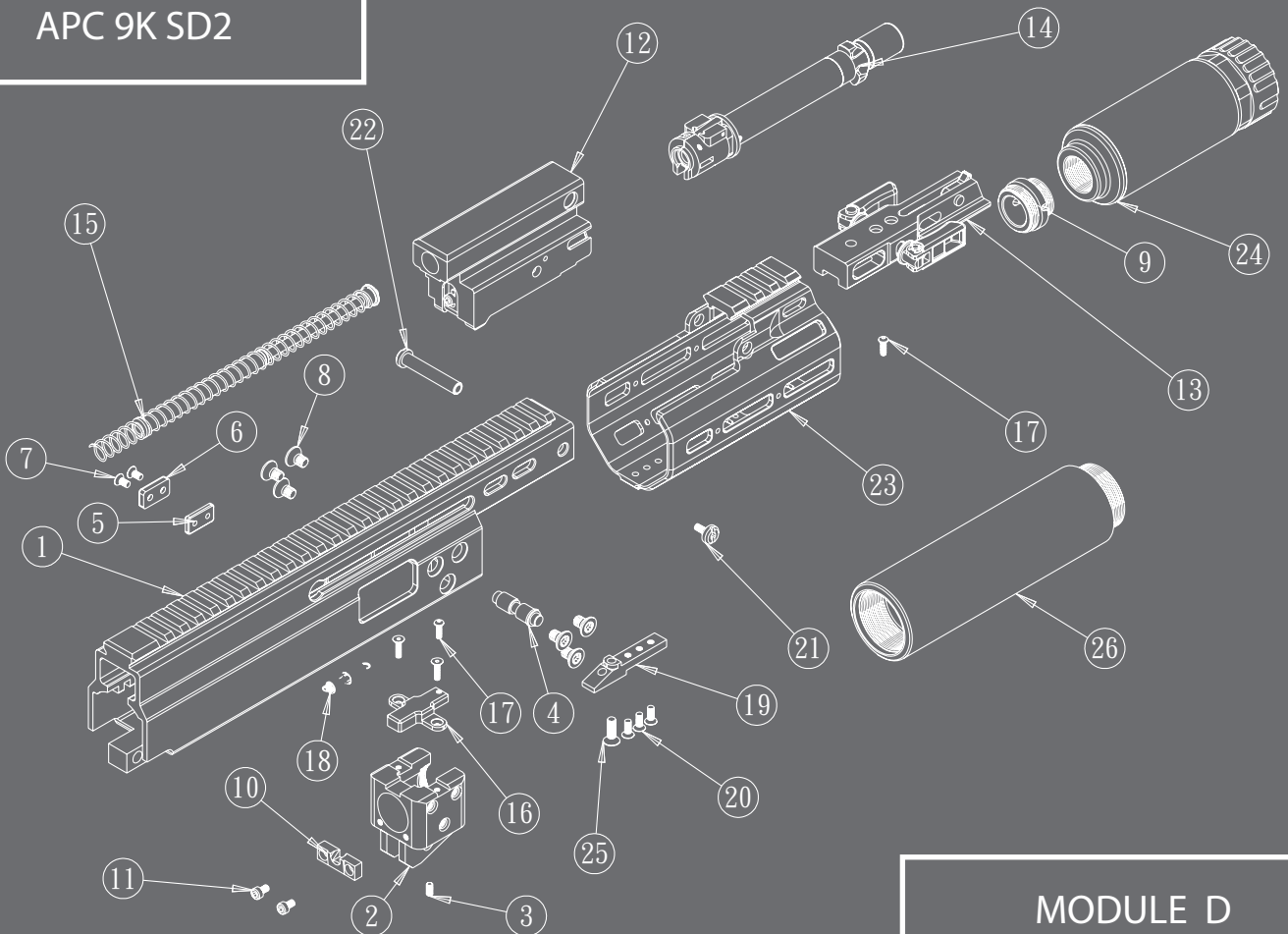

MODULE D

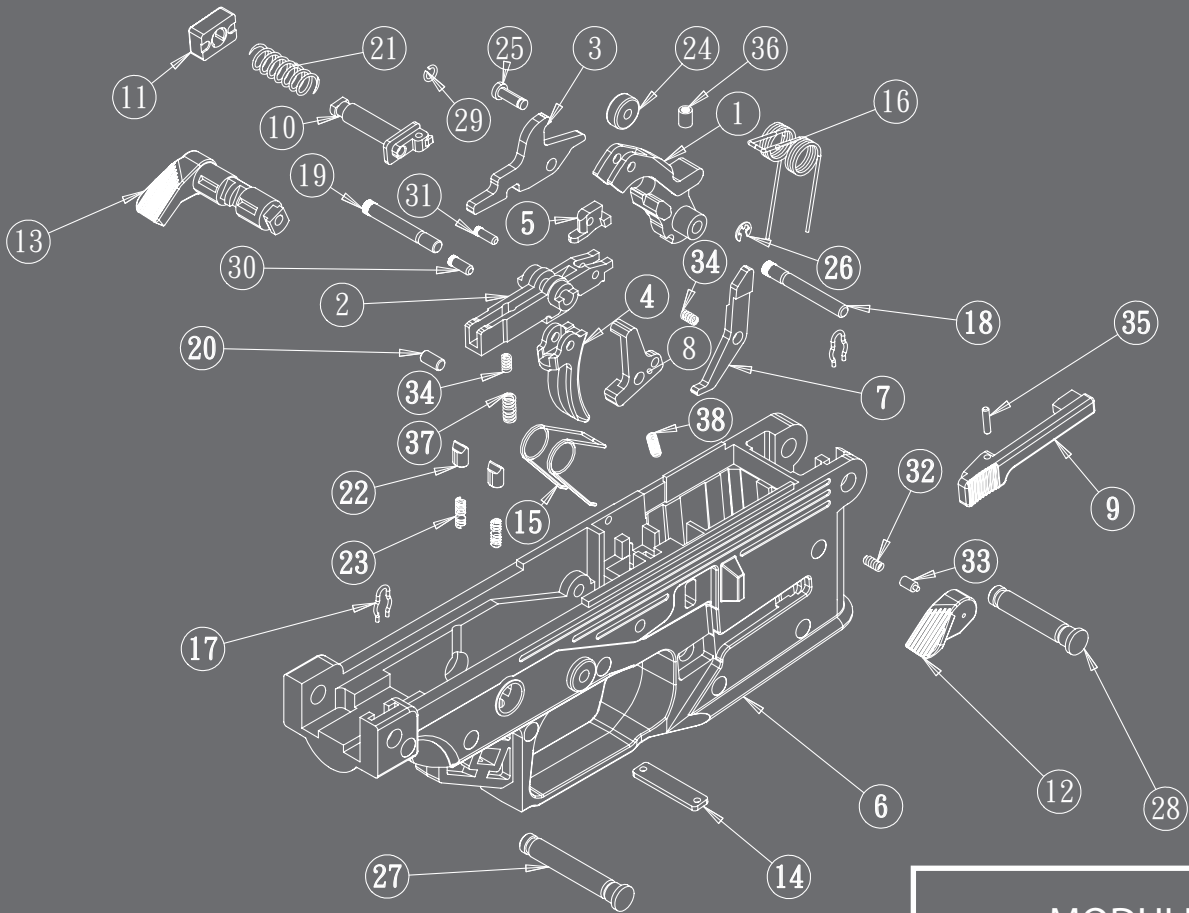

MODULE E

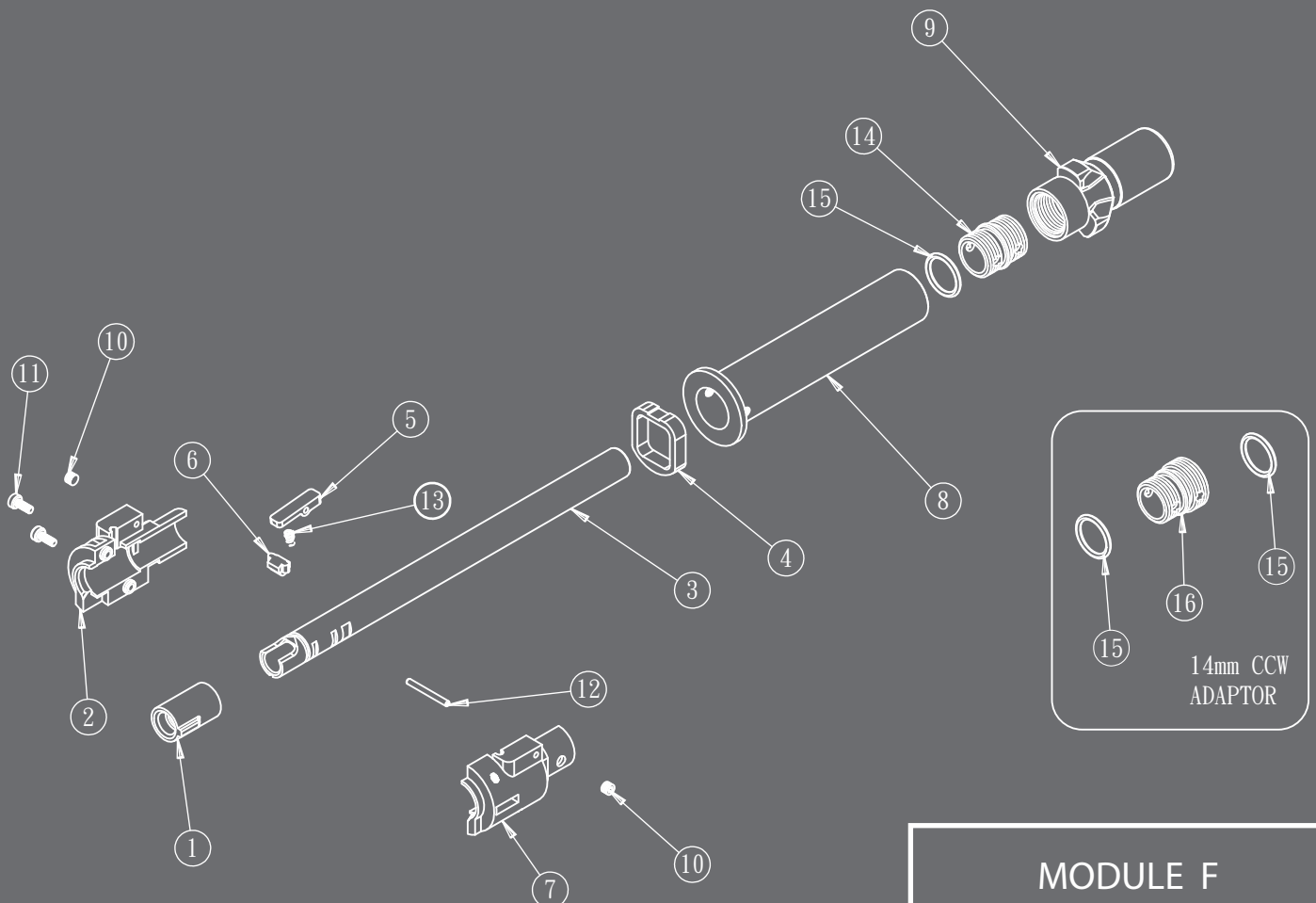

MODULE F

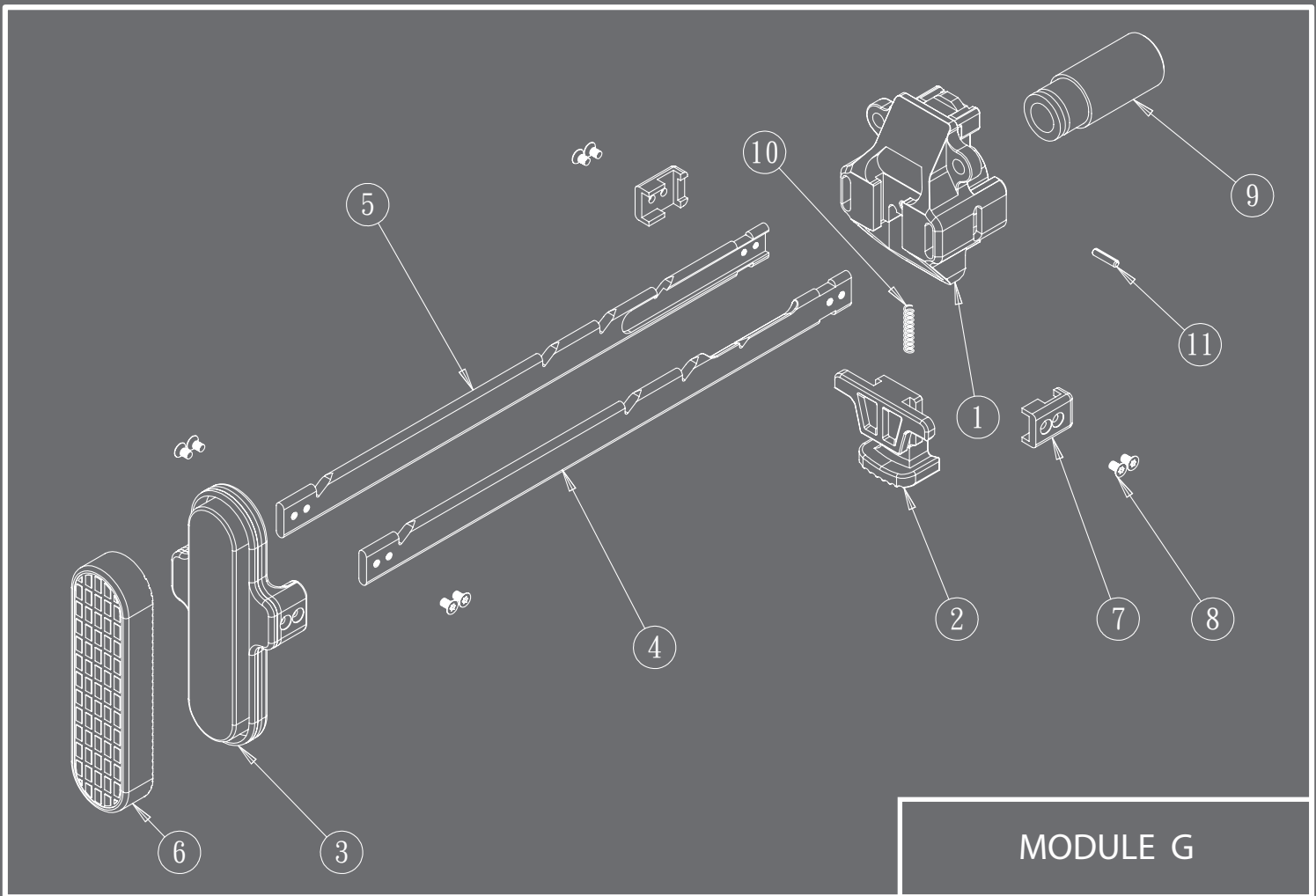

MODULE G

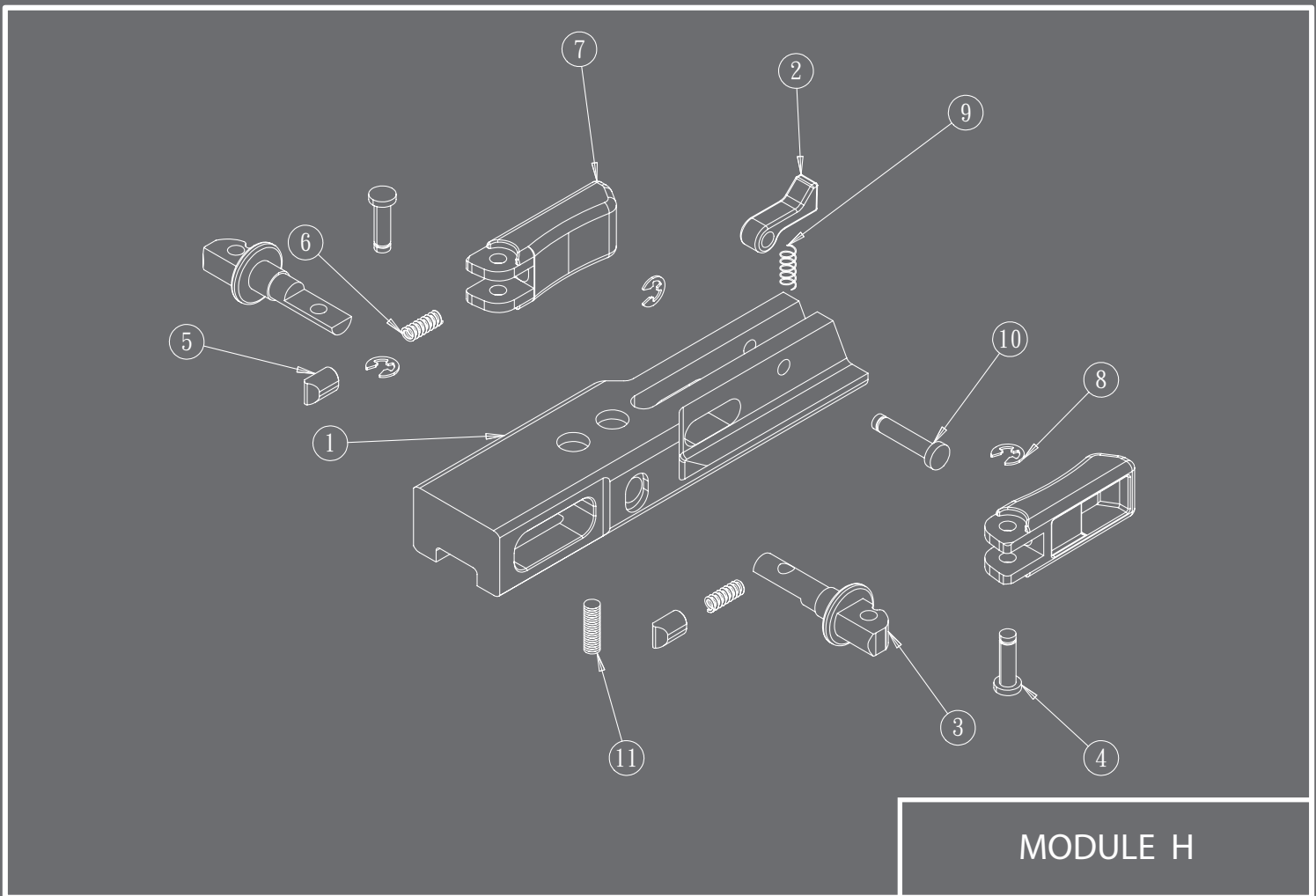

MODULE H

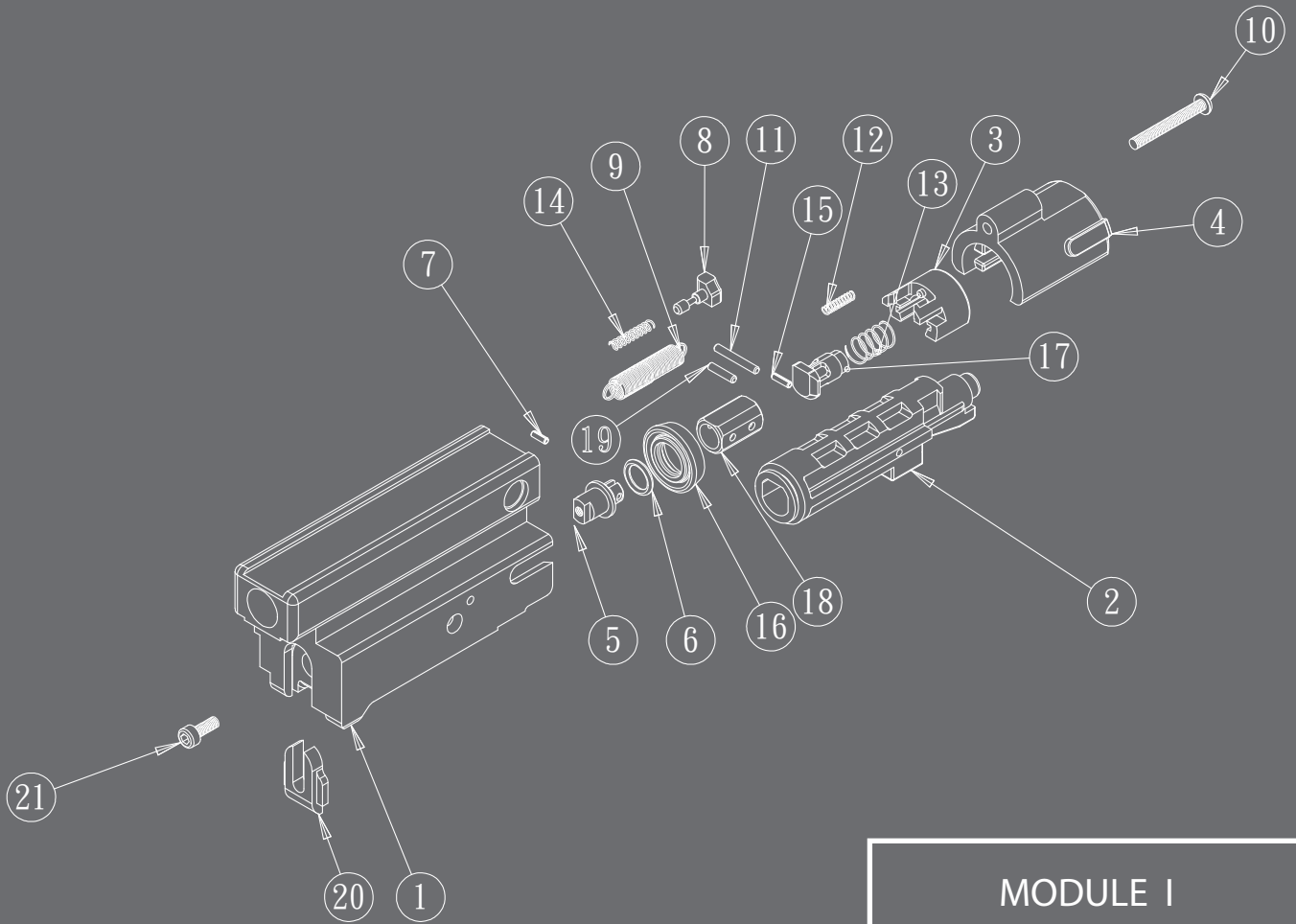

MODULE I

GAS

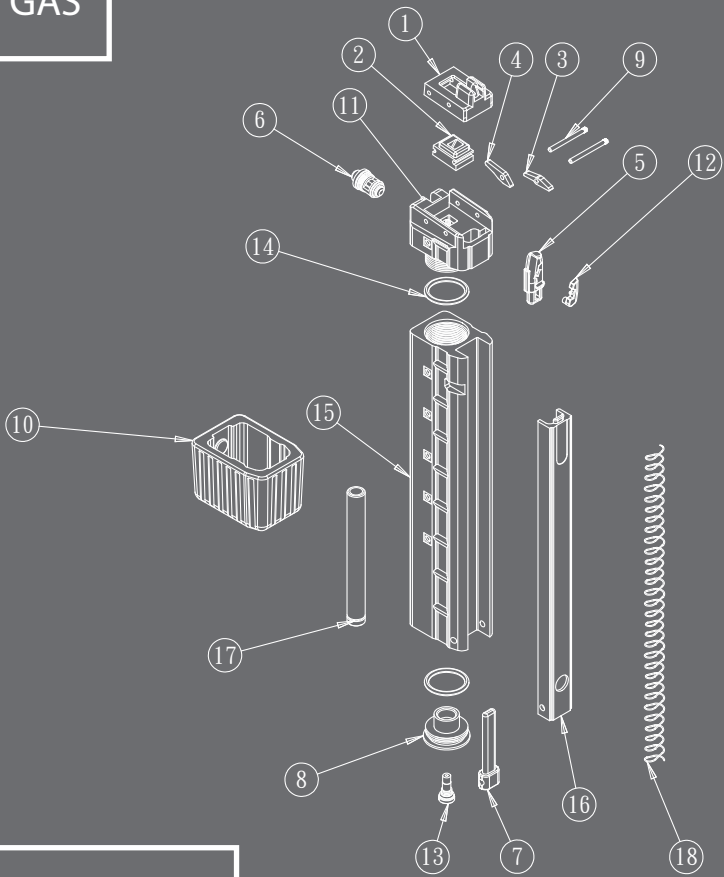

MODULE J

CO2

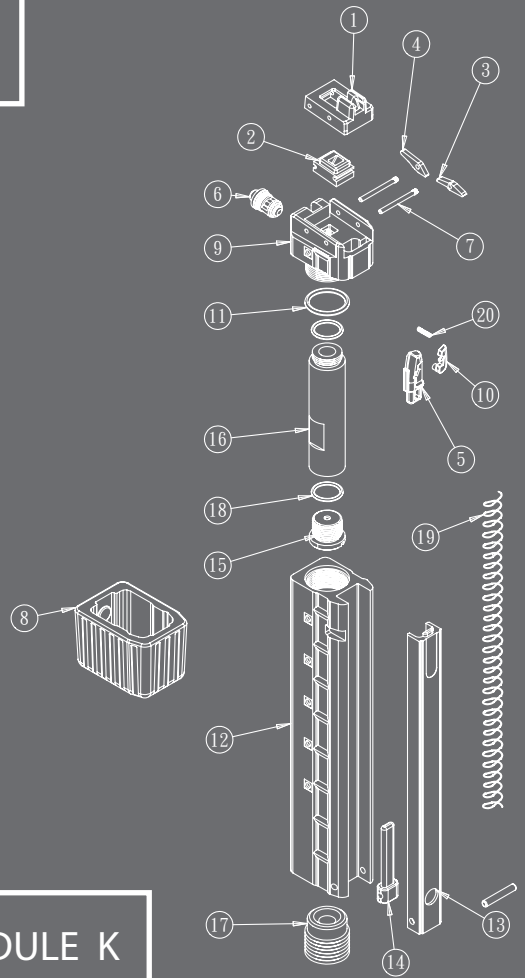

MODULE K

